

SECTION 13—BODY—FRAME

13A—VEHICLE IDENTIFICATION

13B—BODY CONSTRUCTION

13C—SEALER APPLICATION

13D—BODY MOUNTING

13E—FRONT BUMPER

13F—RADIATOR GRILLE

13G—FRONT FENDERS

13H—HOOD

13J—WINDSHIELD

13K—FRONT SEAT

13L—DOORS AND DOOR WINDOWS

13M—QUARTER WINDOWS

13N—BACK WINDOW

13P—LUGGAGE COMPARTMENT

13Q—REAR BUMPER

13R—CONVERTIBLE TOP

13S—STATION WAGON

13T—EXTERIOR MOULDINGS

13U—ELECTRICAL

13W—FRAME

13A—VEHICLE IDENTIFICATION

PATENT PLATE

The patent plate, which includes the serial number, body style, body color, trim code, date of assembly, transmission code, and axle code, is riveted to the left front body pillar, between the front door hinges. See figure 13A-1.

The serial number designates model year of vehicle, assembly plant code letter, body type identification code number, engine code letter, and consecutive unit number.

Model Year

Number one (1) denotes 1961 model year.

Assembly Plant Code Letters

| CODE LETTER | ASSEMBLY PLANT |
|-------------|----------------|
| E | Mahwah |
| J | Los Angeles |
| Z | St. Louis |
| W | Wayne |

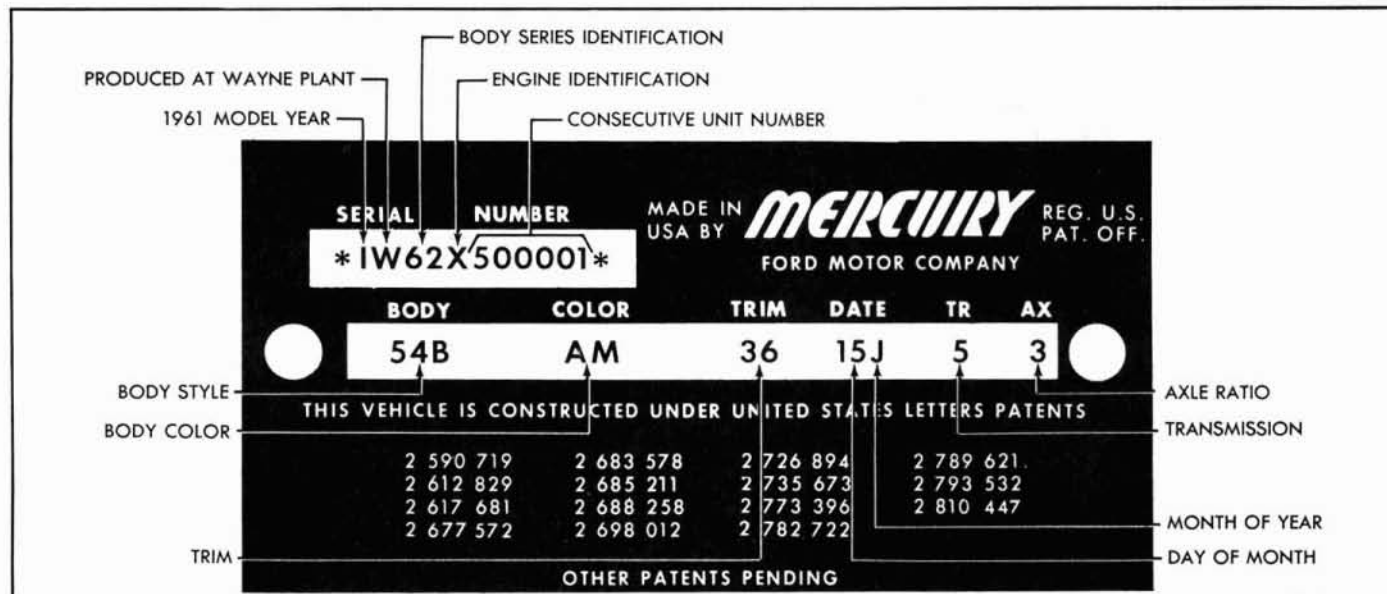

Fig. 13A-1—Patent Plate—(61MM-8008)

Engine Identification Code Letters

| CODE LETTER | ENGINE |
|--------------|---|
| *R | 292 CID 2V Carburetor (Low Compression) |
| *T | 390 CID 4V carburetor (Low Compression) |
| V | 223 CID 1V carburetor |
| W | 292 CID 2V carburetor |
| X | 352 CID 2V carburetor |
| Z | 390 CID 4V carburetor |
| *Export only | |

BODY STYLES

Meteor 600 Series

| BODY STYLE | SERIAL CODE | BODY TYPE |
|------------|-------------|-----------------|
| 64A | 41 | Two-Door Sedan |
| 58A | 42 | Four-Door Sedan |

Meteor 800 Series

| BODY STYLE | SERIAL CODE | BODY TYPE |
|------------|-------------|-------------------|
| 54A | 52 | Four-Door Sedan |
| 62A | 51 | Two-Door Sedan |
| 65A | 57 | Two-Door Hardtop |
| 75A | 54 | Four-Door Hardtop |

Monterey Series

| BODY STYLE | SERIAL CODE | BODY TYPE |
|------------|-------------|----------------------|
| 54B | 62 | Four-Door Sedan |
| 65B | 67 | Two-Door Hardtop |
| 75B | 64 | Four-Door Hardtop |
| 76A | 65 | Two-Door Convertible |

Station Wagons

| BODY STYLE | SERIAL CODE | BODY TYPE |
|------------|-------------|-----------------------|
| 71C | 72 | Four-Door Meteor 600 |
| 71A | 74 | Four-Door Meteor 800 |
| 71B | 76 | Four-Door Colony Park |

Exterior Body Color Codes

A single letter designates a solid body color and two letters denote a two-tone combination—the first letter, the lower color, and the second letter, the upper color. The following chart identifies the basic colors by code letter, name and manufacturing specification numbers.

| CODE LETTER | COLOR | "M" NUMBER |
|-------------|----------------------------|------------|
| A | Presidential Black | M-30J-1724 |
| C | Turquoise Mist | M-30J-1139 |
| D | Blue Haze | M-30J-1361 |
| E | Saxon Green Metallic | M-30J-1364 |
| F | Sunburst Yellow | M-30J-1366 |
| G | Tawny Beige | M-30J-1262 |
| H | Empress Blue Metallic | M-30J-1367 |
| J | Signal Red | M-30J-1232 |
| L | Gold Dust Metallic | M-30J-1276 |
| M | Sultana White | M-30J-1238 |
| Q | Sheffield Gray Metallic | M-30J-1371 |
| R | Columbia Blue Metallic | M-30J-1372 |
| S | Green Frost | M-30J-1373 |
| V | Summer Rose | M-30J-1265 |
| W | Regency Turquoise Metallic | M-30J-1385 |

Interior Trim Identification

A two-digit number indicates the color and type of trim.

A new procedure for Patent Plate identification of Deviation Trim Sets, when Service is affected, has been adopted for 1961.

When Deviation Trim Sets are established against an existing Trim Scheme, Patent Plate Code Identification will be made by adding a numerical suffix after the code if the Trim Set is *not* serviced, such as 23-1 or 23-2; and by adding an alphabetical suffix after the code if the Trim Set *is* serviced, such as 23-A or 23-B.

| CODE NUMBER | MATERIAL AND COLOR |
|-------------|---|
| 01 | Medium Blue Metallic and Dark Blue Luster Weave Cloth |
| 02 | White Vinyl and Black Luster Weave Cloth |
| 03 | Medium Gold Metallic Vinyl and Dark Gold Luster Weave Cloth |
| 05 | Medium Blue Metallic Vinyl and Dark Blue Shadow Weave Cloth |
| 06 | White Vinyl and Black Shadow Weave Cloth |

Interior Trim Identification (Continued)

| CODE NUMBER | MATERIAL AND COLOR |
|-------------|---|
| 08 | Medium Gold Metallic Vinyl and Dark Gold Shadow Weave Cloth |
| 09 | Medium Turquoise Metallic Vinyl and Dark Turquoise Shadow Weave Cloth |
| 10 | Medium Green Metallic Vinyl and Dark Green Shadow Weave Cloth |
| 11 | Medium Blue Metallic Vinyl |
| 12 | White and Black Vinyl |
| 13 | White and Red Vinyl |
| 14 | White and Medium Gold Metallic Vinyl |
| 15 | Medium Turquoise Metallic Vinyl |
| 24 | Medium Blue Metallic Vinyl and Dark Blue Country Tweed Broadcloth |
| 25 | White Vinyl and Black Country Tweed Broadcloth |
| 27 | Medium Gold Metallic Vinyl and Dark Gold Country Tweed Broadcloth |
| 29 | Medium Turquoise Metallic Vinyl and Dark Turquoise Country Tweed Broadcloth |
| 30 | Medium Turquoise Metallic Vinyl and Dark Turquoise Luster Weave Cloth |
| 32 | Red Vinyl |
| 33 | Black Vinyl |
| 34 | Medium Blue Vinyl and Medium Blue Oval Tweed Cloth |
| 35 | White Vinyl and Medium Gray Oval Tweed Cloth |
| 36 | Red Vinyl and Medium Gray Oval Tweed Cloth |
| 37 | Medium Turquoise Vinyl and Medium Turquoise Oval Tweed Cloth |

| CODE NUMBER | MATERIAL AND COLOR |
|-------------|---|
| 43 | Brown Rib Morocco Vinyl (Police and Taxi) |
| 44 | Green Rib Morocco Vinyl (Police and Taxi) |
| 45 | Red Rib Morocco Vinyl (Police and Taxi) |

Day and Month of Year Code

The number indicates the day of month vehicle was built and the letter indicates the month. Following is the month of year code chart:

| CODE LETTER | MONTH | CODE LETTER | MONTH |
|-------------|----------|-------------|-----------|
| A | January | G | July |
| B | February | H | August |
| C | March | J | September |
| D | April | K | October |
| E | May | L | November |
| F | June | M | December |

Transmission Code

The transmission code number indicates the type of transmission installed in the vehicle.

| CODE NUMBER | TYPE OF TRANSMISSION |
|-------------|--------------------------------------|
| 1 | Standard |
| 2 | Standard with Overdrive |
| 3 | Automatic—Single Range (Two-Speed) |
| 4 | Automatic—Dual Range (Three-Speed) |
| 5 | Automatic—Single Range (Three-Speed) |

Rear Axle Ratio Code

The rear axle ratio code number indicates the ratio of the axle installed in the vehicle.

| CODE NUMBER | AXLE RATIO | CODE NUMBER | AXLE RATIO |
|-------------|------------|-------------|------------------|
| 1 | 3.56:1 | 8 | 2.91:1 |
| 2 | 3.89:1 | 9 | 3.70:1 |
| 3 | 3.10:1 | A | 3.56:1 (Locking) |
| 4 | 3.78:1 | B | 3.89:1 (Locking) |
| 6 | 3.22:1 | C | 3.10:1 (Locking) |

INTERIOR PAINT COLORS

The following colors and manufacturing specification codes will identify interior paints or finishes by type. These paints or finishes are not identified by patent plate codes.

Semi-Gloss Enamels

| "M" NUMBER | COLOR |
|--------------|-----------------------|
| M-21J-1386-C | Medium Blue Metallic |
| M-21J-1387-C | Medium Green Metallic |
| M-21J-1388-C | Turquoise Metallic |
| M-21J-1389-C | Medium Brown Metallic |
| M-21J-1413-C | Medium Gold Metallic |
| M-21J-1429-C | Red |
| M-21J-1724-C | Black |
| M-21J-1433-C | Cream |

13B—BODY CONSTRUCTION

DESCRIPTION

The body is of all-steel construction, consisting of major panels, reinforcements, and braces welded together

into one unit.

Figures 13B-1, 13B-2, 13B-3 and 13B-4 illustrate many of the major assemblies used in the body construction.

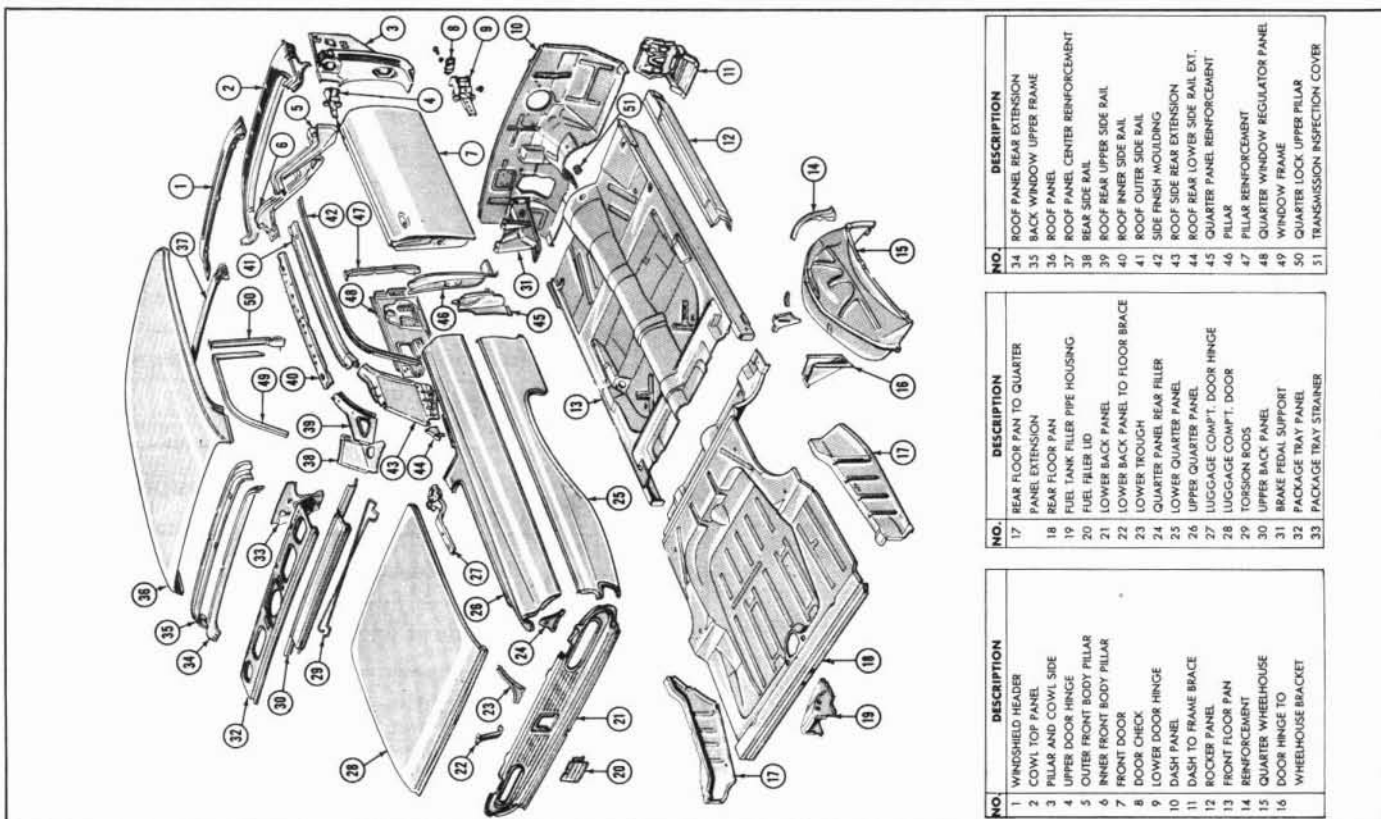

Fig. 13B-1—Body Construction—Model 62—(61MM-8059)

From ADVANCED MAINTENANCE MANUAL FOR 1961 (FORM MD-6077-61)